

FLEXFLO[®]

Peristaltic Metering Pump



Series M1

1.0	Introduction	4
	1.1 Available Models	4
	1.2 What's in the Box	4
2.0	Engineering Specifications	5
3.0	Materials of Construction	6
	3.1 Wetted Components	6
	3.2 Non-Wetted Components	6
4.0	Features	7
	4.1 Agency Listings	7
5.0	Installation	8
	5.1 Mounting Location	8
	5.2 Pump Dimensions	8
	5.3 Wall Mounting	9
	5.4 Power Connections	10
	5.5 Input / Output Connections	12
	5.6 M12 Connections	12
6.0	Touchpad Layout	13
7.0	Set-Up, Programming, and Inputs	14
	7.1 Remote Start / Stop	15
	7.2 Programming FVS (Flow Verification Sensor)	16
	7.3 Pump Lockout	17
	7.4 4-20ma Input	18
8.0	Pump Operation	19
	8.1 Priming the Pump	19
	8.2 Manual Speed/Flow Adjust	20
	8.3 4-20mA Speed/Flow Control	21
9.0	Outputs	22
	9.1 Motor ON	22
	9.2 Relay (FVS and TFD)	22
	9.3 4-20mA Output	22
10.0	Tube Failure Detection (TFD+)	22
	10.1 Confirming Chemical Detection	22
11.0	Pump Maintenance	23
	11.1 Routine Inspection and Maintenance	23
	11.2 Cleaning and Lubricating the Pump	23
12.0	Tube Replacement	24
	12.1 Provided Tool	24
	12.2 Tube Removal	24
	12.3 Tube Installation	26
13.0	Firmware Update	28
14.0	Replacement Parts List	30
	14.1 Exploded View	30
15.0	Accessories	32
16.0	Troubleshooting	34
17.0	Warranty	35
APPENDIX A: ACRONYMS		36
APPENDIX B: MODEL NUMBER MATRIX		37

READ THE ENTIRE OPERATING MANUAL PRIOR TO INSTALLATION AND USE.



+1 (714) 893 - 8529



sales@blue-white.com



customerservice@blue-white.com



5300 Business Drive
Huntington Beach, CA 92649

1.0 INTRODUCTION

Congratulations on purchasing Blue-White FLEXFLO® Series M1 peristaltic metering pump (a peristaltic metering pump is a type of positive displacement pump used for pumping a variety of fluids).

The FLEXFLO® Series M1 peristaltic metering pump is pre-configured for the tubing that is shipped with it.

NOTE: For accurate calibration of pump tube, run the pump for one hour with new tube installed prior to calibration.

NOTE: The tubing has an identification number printed on the tube for easy re-ordering.

NOTE: The pump was pressure-tested at the factory with clean water before it was shipped. There may be trace amounts of clean water in the pre-installed tube assembly.

1.1 Available Models

Model Number Matrix

M1

FLEXFLO® Model Number

M1	FLEXFLO® Peristaltic Metering Pump				
Power Cord (Operating voltage requirement 96VAC to 264VAC)					
4	115V 50/60Hz, power cord NEMA 5/15 plug (US) (detachable - 6 ft)				
6	220V 50/60Hz, power cord CEE 7/11 plug (EU) (detachable - 6 ft)				
X	No Power Cord				
Pump Tube Size and Material					
1	1/4" OD Flex-A-Thane® 0.0001 - 1.09 GPH .0069 - 69 mL/Min 65 PSI (4.5 bar)				
3	7/16" OD Flex-A-Thane® 0.0005 - 5.60 GPH .0353 - 353 mL/Min 50 PSI (3.45 bar)				
4	1/4" OD Flex-A-Prene® 0.0001 - 0.44 GPH .0028 - 28 mL/Min 100 PSI (6.89 bar)				
6	3/8" OD Flex-A-Prene® 0.0001 - 1.35 GPH .0085 - 85 mL/Min 100 PSI (6.89 bar)				
7	7/16" OD Flex-A-Prene® 0.0004 - 4.17 GPH .0263 - 263 mL/Min 50 PSI (3.45 bar)				
8	7/16" OD Flex-A-Chem® 0.0003 - 3.09 GPH .0195 - 195 mL/Min 50 PSI (3.45 bar)				
Inlet/Outlet Connection Size, Connection Type					
T	3/8" OD x 1/4" ID Tube Compression Fitting				
M	1/2" Male NPT Fitting				
MB	1/2" Male BSPT Fitting, Natural PVDF (Kynar)				
M1	4	-	1	T	Sample Model Number

1.2 What's in the Box

- Blue-White FLEXFLO® Series M1 peristaltic metering pump
- Power Cord
- Two (2) Tube assemblies (one installed, one spare)
- Mounting Hardware Kit / Rear Bracket
- Display Shield
- Instruction Manual

See Accessory page for additional options (Suction / Discharge Tubing, Injection Valves, Suction Strainer, M12 communications cables, Wall Mount Bracket.)

2.0 ENGINEERING SPECIFICATIONS

Maximum Working Pressure (Excluding pump tubes)¹	100 PSI (6.89 bar)
Maximum Fluid Temperature¹	185°F (85°C)
Maximum Viscosity	5000 centipoise
Maximum Suction Lift	30 ft. of water at sea level (14.7 atm psi)
Ambient Operating Temperature Range	14°F to 115°F (-10°C to 46°C)
Ambient Storage Temperature Range	-40°F to 158°F (-40°C to 70°C)
Operating Voltage	115V60Hz 1 PH (0.6A max.) 220V50Hz 1 PH (0.3A max.) 230V60Hz 1 PH (0.3A max.) 230V50Hz 1 PH (0.3A max.) 240V50Hz 1 PH (0.3A max.)
Power Cord Options (removable)	115V60Hz = NEMA 5/15 (USA) 230V60Hz = NEMA 6/15 (USA) 220V50Hz = CEE 7/VII (EU) 240V50Hz = AS 3112 (Australia/New Zealand) 230V50Hz = BS 1363/A (UK)
Motor	Brushless DC, 50W.
Duty Cycle	Continuous
Motor Speed Adjustment Range	10,000:1 (0.01% - 100%) Max rpm = 65 rpm
Enclosure	NEMA 4X (IP66), Valox® (PBT) & PA12
Maximum Overall Dimensions	7.25" W x 9" H x 10" D (18.5 W x 22.9 H x 25.2 D cm)
Product Weight	6 lb. (2.7 Kg)
Approximate Shipping Weight	13 lb. (5.9 Kg)
Approximate Shipping Dimensions	10.5" W x 13.75" H x 11" D (26.7 W x 35 H x 28 D cm)
RoHS Compliant	Yes
Standards	NSF/ANSI 61, cETLus, CE

1. Refer to individual tube pressure and temperature ratings.

3.0 MATERIALS OF CONSTRUCTION

3.1 Wetted Components

Pump Tube Assembly

Tubing	Flex-A-Prene®, Flex-A-Thane®, Flex-A-Chem®
Adapter Fittings	PVDF (1/4" x 3/8" Tubing Connection, or 1/2" MNPT)

3.2 Non-Wetted Components

Enclosure

Valox® (PBT) & PA12

Pump Head

Valox® (PBT)

Pump Head Cover

Polycarbonate
Permanently lubricated sealed motor shaft support ball bearing.

Cover Screws

Stainless steel, polypropylene cap

Roller Assembly

Rotor	Valox® (PBT)
Rollers	Nylon
Roller Bearings	Bronze

TFD+ System Sensor

Polysulfone (PES)

Power Cord

3 conductor, SJTW-A water-resistant

Tube Installation Tool

GF nylon

Mounting Brackets and Hardware

316 stainless steel screws
GF nylon bracket

4.0 FEATURES

- ▶ Tube Failure Detection (TFD+) senses tube failure and shuts off the pump. No false triggering.
- ▶ Heavy duty display shield protects pump controls.
- ▶ Remote Start/Stop - one non-powered dry contact closure.
- ▶ Compatible with Blue-White Flow Verification Sensor (FVS) system.
- ▶ Outputs: 4-20mA, single 250V/3A (TFD or FVS), and a solid state “motor on” (0-60VDC sinking)
- ▶ Self-priming, cannot vapor lock or lose prime.
- ▶ Speed Control: Manual Speed Adjust and Scalable 4-20mA Input
- ▶ Convenient M12 Connectors (IP67) for Input/Output Communications.(M12 cables ordered separately)

4.1 Agency Listings



This pump is ETL listed to conforms to the following: UL Standard 778 as a motor operated water pump. CSA Standard C22.2 as process control equipment

Intertek



This pump complies to the Machinery Directive 2006/42/EC, BS, EN 60204-1, Low Voltage Directive 2014/35/EU BS EN 61010-1, EMC Directive 2014/30/EU, BS EN 50081-1/BS EN 50082-1.



This pump is certified to NSF/ANSI Standard 61- Drinking Water System Components - Health Effects

Certified to NSF/ANSI Standard 61

Symbol	Description
	Warning (Risk of electric shock)
	Caution (Refer to the user's guide)
	Ground, Protective Conductor Terminal

ENCLOSURE RATING

NEMA 4X Constructed for either indoor or outdoor use to provide a degree of protection to personnel against incidental contact with enclosed equipment; to provide a degree of protection against falling dirt, rain, sleet, snow, windblown dust, splashing water, and hose-directed water; and that will be undamaged by external formation of ice on enclosure.

IP66 No ingress of dust; complete protection against contact. Water projected in powerful jets against enclosure from any direction shall have no harmful effects.

5.0 INSTALLATION

CAUTION



The pump should be serviced by qualified persons only. If equipment is used in a manner not specified in this manual, the protection provided by the equipment may be impaired.

CAUTION



Always wear protective clothing, face shield, safety glasses and gloves when working on or near your metering pump. Additional precautions should be taken depending on solution being pumped. Refer to MSDS precautions from your solution supplier.

CAUTION



All diagrams are strictly for guideline purposes only. Always consult an expert before installing metering pump on specialized systems. Metering pump should be serviced by qualified persons only.

CAUTION



Check system pressure and piping/tubing pressure limits before installing. If using pump with chemicals that off-gas (i.e. sodium hypochlorite), do not leave chemicals in pump or between valves for excessive periods of non-use. Flush pump as necessary.

CAUTION



The pump should be supplied by an isolating transformer or RCD (operating current less or equal 30 mA).

5.1 Mounting Location

1. **The pump must be sheltered from environment (rain, snow, direct sunlight, etc.) Do not place pump on floor or in location with excessive chemical spills or vapors.**
2. Choose an area located near the chemical supply tank, chemical injection point, and electrical supply. Also, choose an area where the pump can be easily serviced.
3. Find a secure and level surface and mount the pump close to the injection point. Keep the inlet (suction) and outlet (discharge) tubing as short as possible. Longer discharge tubing increases back pressure at pump head.

NOTE: Mounting the pump lower than the chemical container will gravity-feed chemical into it. This “flooded suction” installation may minimize output variation by eliminating suction lift, and minimizing air and gasses entering the pump due to off-gassing and suction line leaks. A shut-off valve, pinch-clamp, or other means to halt gravity-feed to the pump must be installed during servicing.

NOTE: Install a back flow prevention check valve at the discharge side of the pump to prevent the system fluid from flowing back through pump during tube replacement or during tube leak.

NOTE: A pressure relief valve is recommended at the discharge side of the of pump to prevent premature wear and damage to the pump tube, in the event that the discharge line becomes blocked.

NOTE: The pump does not require back pressure. Keep the discharge pressure as low as possible to maximize the tube life.

5.2 Pump Dimensions

Dim	Inch	cm	Dim	Inch	cm
A	9.46"	24.02	D	7.18"	18.23
B	9.92"	25.19	E	1.5"	3.81
C	7.18"	18.23			

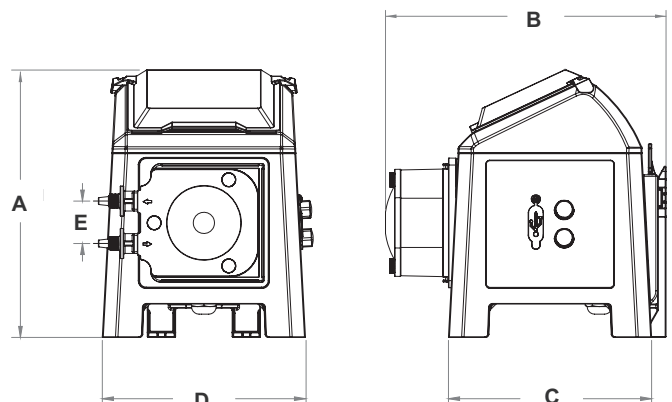

5.3 Wall Mounting

- Using #10 self-tapping screws, or appropriate hardware for the wall material, mount the bracket to a secure wall that is located no higher than 4 feet above ground for easy programming and service.

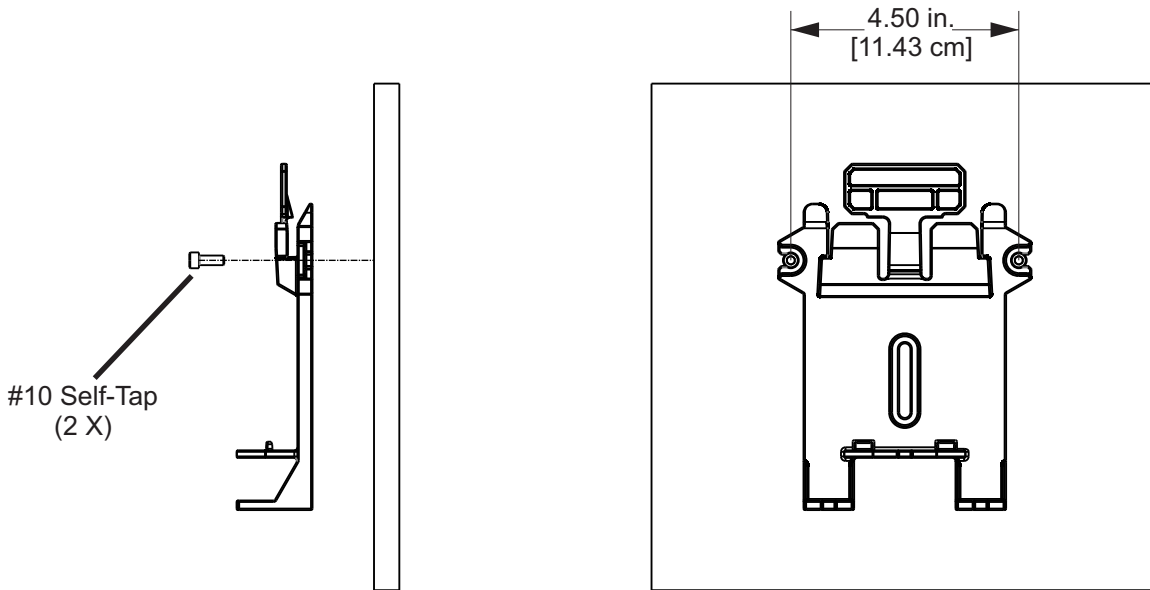

Wall/Shelf Mount Bracket (Side View)

Mounted Pump (Front View)

Note: If mounting bracket to shelf, table, or floor, we recommend using mounting holes on bracket feet and using hardware appropriate for base surface. See Accessories for Wall Shelf options.

- Lower the pump so that the tab on the wall mount is inserted into the slot located on the back of the pump. The pump will now be secured to the mount bracket. To remove, pull tab forward and lift pump.

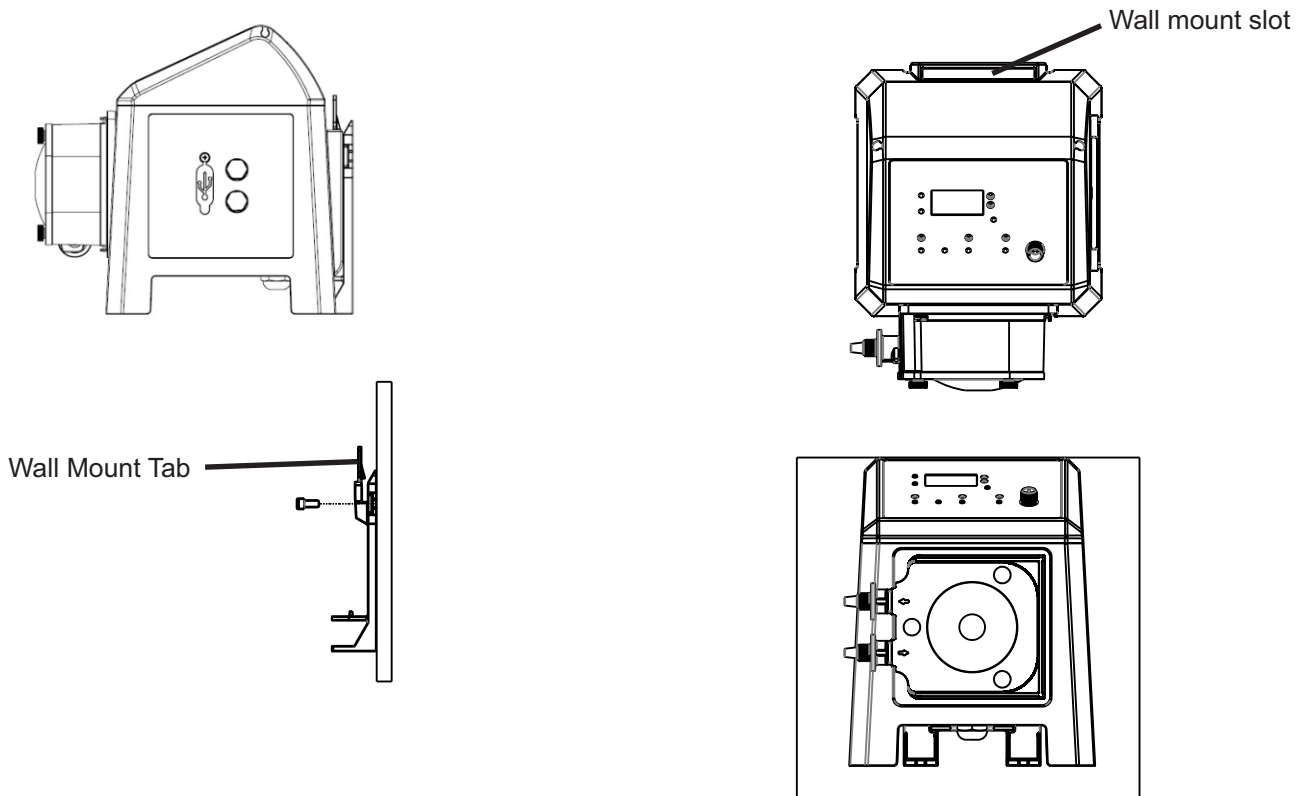

Wall Mount (Side View)

Mounted Pump

5.4 POWER CONNECTIONS

WARNING

Risk of electric shock – cord connected models are supplied with a grounding conductor and grounding-type attachment plug. To reduce risk of electric shock, be certain that it is connected only to a properly grounded, grounding-type receptacle.

WARNING

Electrical connections and grounding (earthing) must conform to local wiring codes.

WARNING

Ensure to connect the pump to the proper supply voltage. Using the incorrect voltage will damage the pump and may result in injury. The voltage requirements is printed on the pump serial label.

- ▶ Use the voltage for which the power cord is rated.
- ▶ To prevent electronic noise interference, electronic signal wires and AC power wires must be kept separate. Do not bundle these cables together or run within the same conduit.
- ▶ When there is a power interruption, the pump will restart (resume) in the same state as prior to power interruption.
- ▶ POWER: 115V60Hz (0.6A max.), 220V50Hz (0.3A max.), 230V60Hz (0.3A max.), 230V50Hz (0.3A max.), 240V50Hz (0.3A max.)
- ▶ **COVERS FOR USB CONNECTION AND M12 CONNECTIONS MUST BE IN PLACE WHEN NOT CONNECTED TO CABLES**

NOTE: When in doubt regarding your electrical installation, contact a licensed electrician.

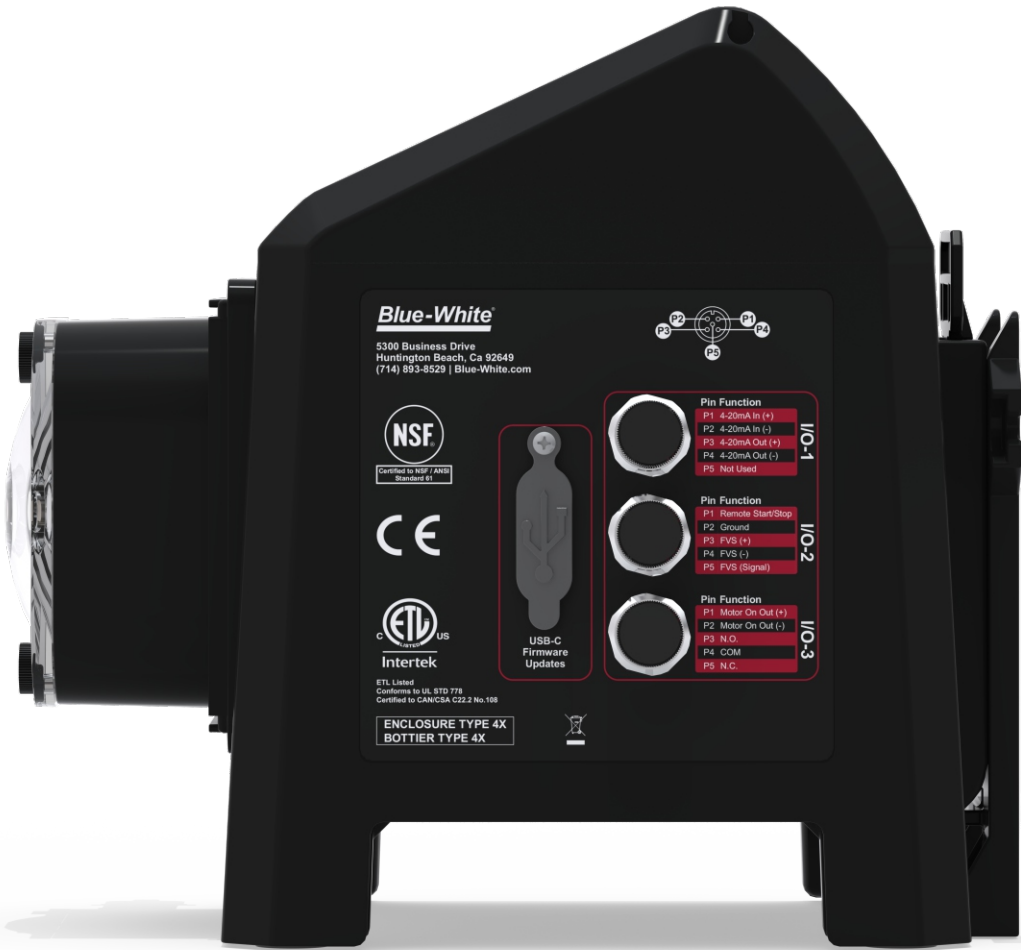

Pump (Right Side Panel)

5.5 IO Connection



Risk of electric shock - All wiring must be insulated and rated 60V minimum.

COVERS FOR USB CONNECTION AND M12 CONNECTIONS MUST BE IN PLACE WHEN NOT CONNECTED TO CABLES (Failure to keep connectors in place may void warranty)

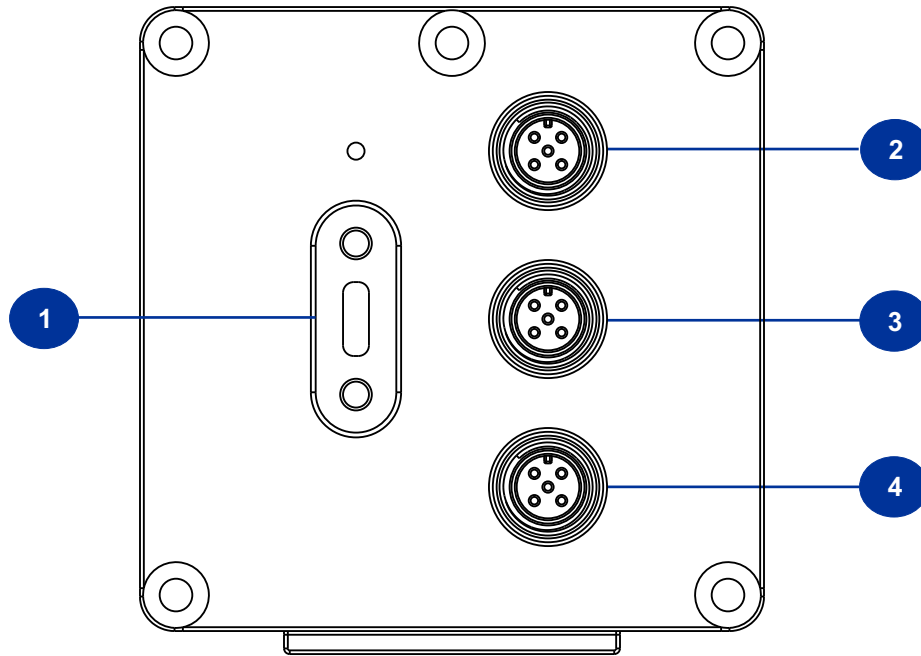

Pump (Right Side Panel)

Item Number	Item
1	USB-C Connector
2	M12 Input Connector I/O 1
3	M12 Input Connector I/O 2
4	M12 Output Connector I/O 3

M12 cables not included with product. See Accessories for M12 cable options.

*A-Type M12 connector with 5 position female sockets required.
Shielded cable should be used on all signal wires.*

5.6 M12 Connector

Warning! Never allow M12 cable wires to touch while the pump is active. Wiring shorts will cause the pump to malfunction and can void the warranty. Protect or tape unused wires as necessary.

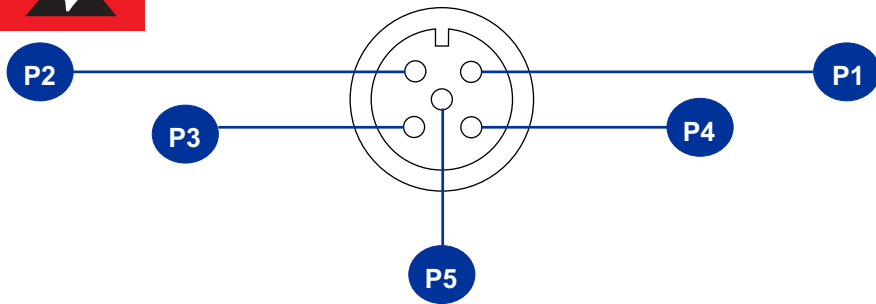

Blue-White M12 Cable Wiring		
DIAGRAM	PIN #	WIRE
	PIN 1	BROWN
	PIN 2	WHITE
	PIN 3	BLUE
	PIN 4	BLACK
	PIN 5	GRAY

M12 Input Connector I/O 1

PIN	Function	Specifications	Reference
P1	4-20mA Input (+)	120 Ohm Impedance, Non powered loop	(+) Positive
P2	4-20mA Input (-)	120 Ohm Impedance, Non powered loop	(-) Negative
P3	4-20mA Output (+)	250 Ohm Max Load	(+) Positive
P4	4-20mA Output (-)	DC GND (0 VDC)	(-) Negative
P5	Not Used		

M12 Input Connector I/O 2

PIN	Function	Specifications	Reference
P1	Remote Start / Stop	Dry Contact Closure (Do Not add voltage)	Green Light = Normally Open Red Light = Normally Closed
P2	Ground	DC Ground	0 VDC
P3	FVS (+)	15 VDC @ 60 mA	To power FVS sensor
P4	FVS (-)	DC Ground (0 VDC)	FVS Ground Input
P5	FVS (Signal)	Input Signal	Input for FVS Signal

M12 Output Connector I/O 3

PIN	Function	Specifications
P1	Pump Motor Running (+)	0-60VDC sinking output (+) Solid State Contact Closure
P2	Pump Motor Running (-)	0-60VDC sinking output (-) Solid State Contact Closure
P3	N.O. (closes with TFD or FVS alarm)	Relay Out, N.O. Contact 3 Amp @ 250 VAC
P4	COM	Relay Out, COM Contact
P5	N.C. (opens with TFD or FVS alarm)	Relay Out, N.C. Contact 3 Amp @ 250 VAC

6.0 TOUCHPAD LAYOUT

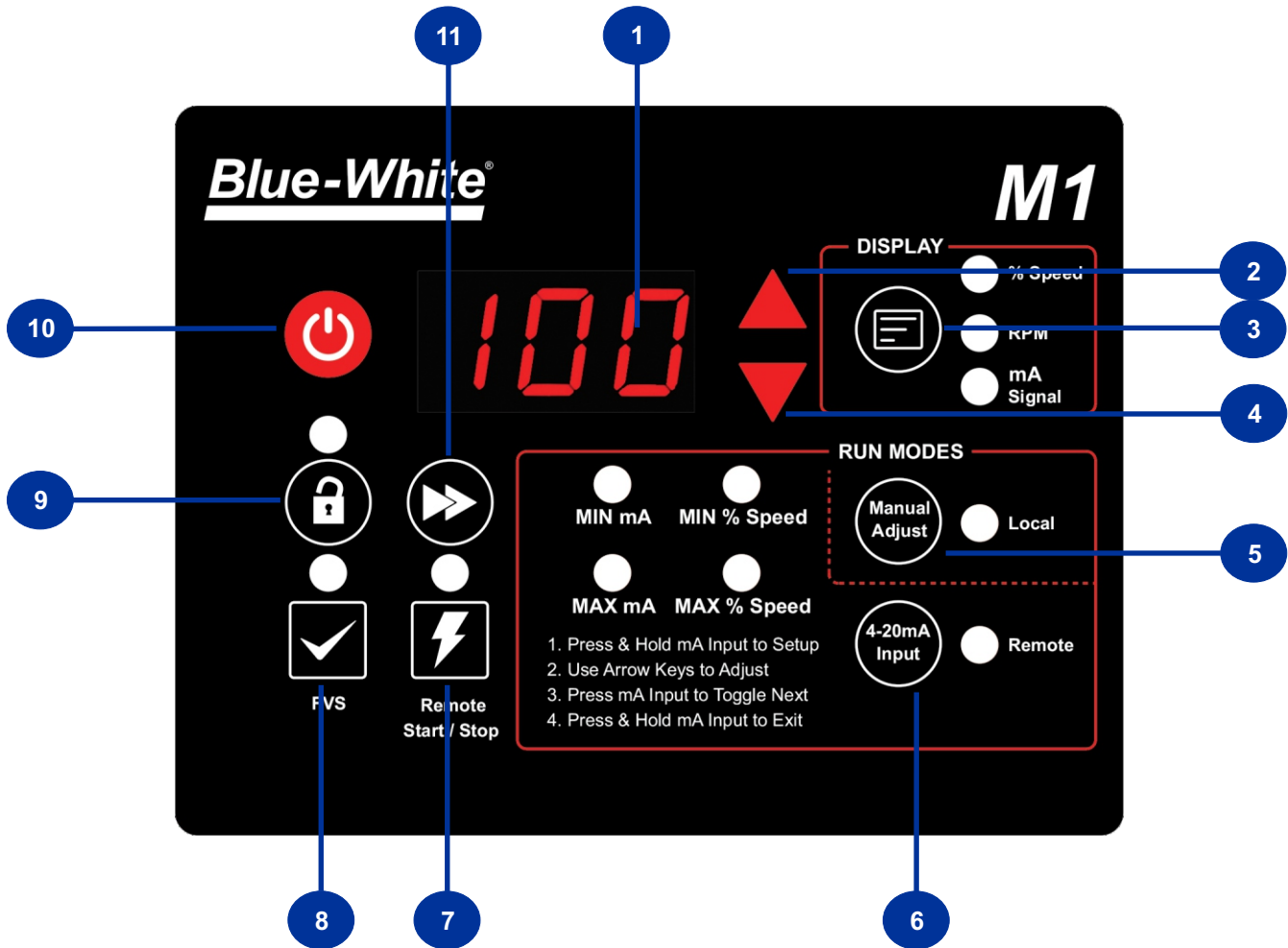

Item Number	Item
1	LED/LCD Readout
2	Up Key
3	Rate Display Key
4	Down Key
5	Manual Adjust Control
6	4-20mA Input Control
7	Remote Start/Stop Key
8	Flow Verification Sensor (FVS) Key
9	Lock-Out Key
10	Start & Stop Key
11	Prime Key

7.0 SET-UP AND PROGRAMMING

7.1 Remote Start/Stop

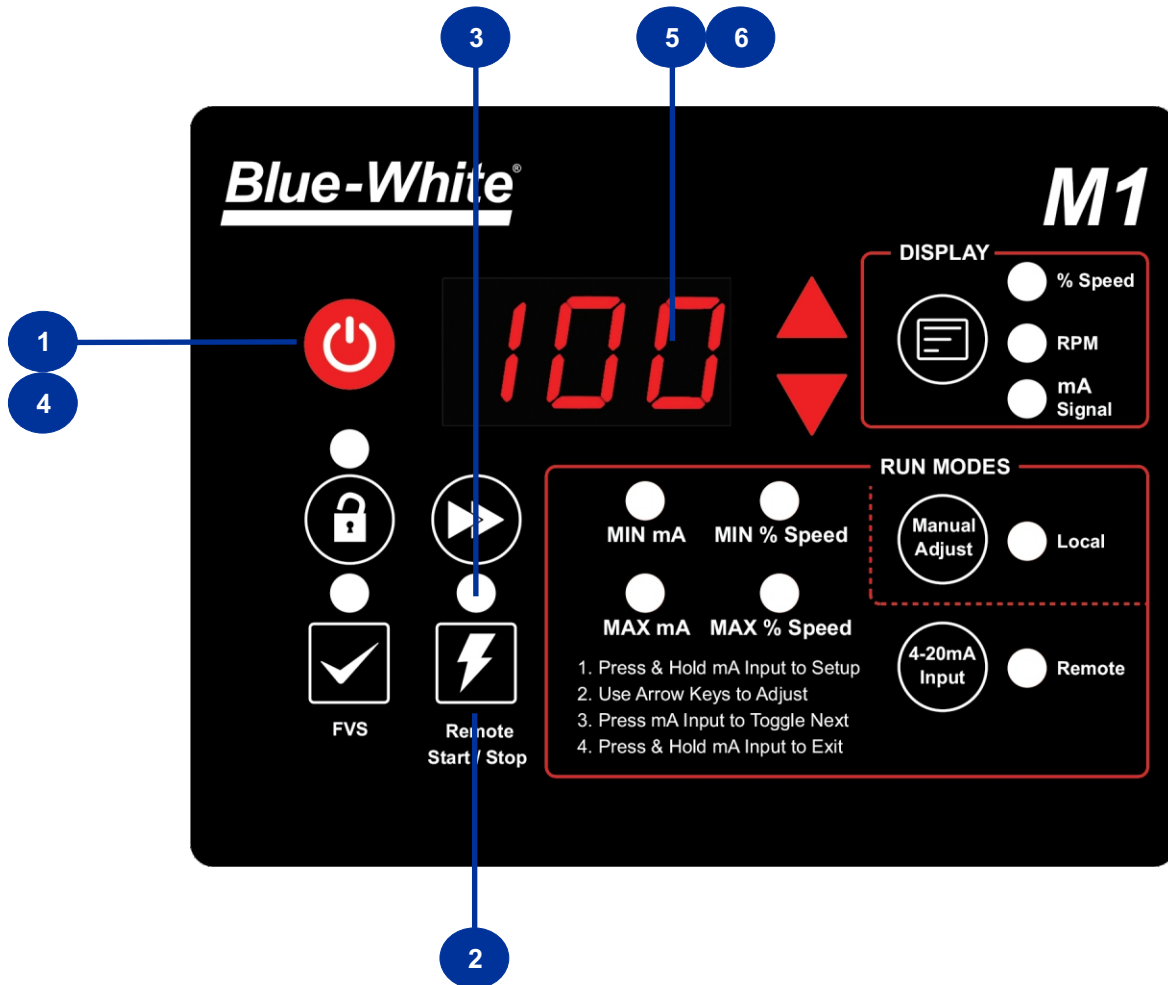

Item Number	Directions for Normally Open Operation
-------------	--

1	Confirm that pump is in the OFF position
2	Press Remote Start/Stop button to activate
3	Light will turn Green for "Normally Open" Operation
4	To put pump is Ready state, press Start/Stop button
5	Display will show "SIG" when waiting for contact closure signal
6	Display will show pump speed (or RPM, 4-20ma) when signal is closed

Item Number	Directions for Normally Closed Operation
-------------	--

1	Confirm that pump is in the OFF position, and Remote Start/Stop light is off
2	Press and hold Remote Start/Stop button for 5-7 seconds
3	Light will turn Red for "Normally Closed" Operation
4	To put pump is Ready state, press Start/Stop button
5	Display will show "SIG" when waiting for contact closure to Open
6	Display will show pump speed (or RPM, 4-20mA) when signal is Open

7.2 Programming FVS (Flow Verification Sensor)

Flow Verification System (FVS) uses pulse signal from flow meter/sensor. When FVS feature is activated, if running pump does not receive signal/pulse in the programmed delay time, the pump will stop and activate Alarm Output Relay. Display will read “FuS”. Contact Blue-White for sensor options.

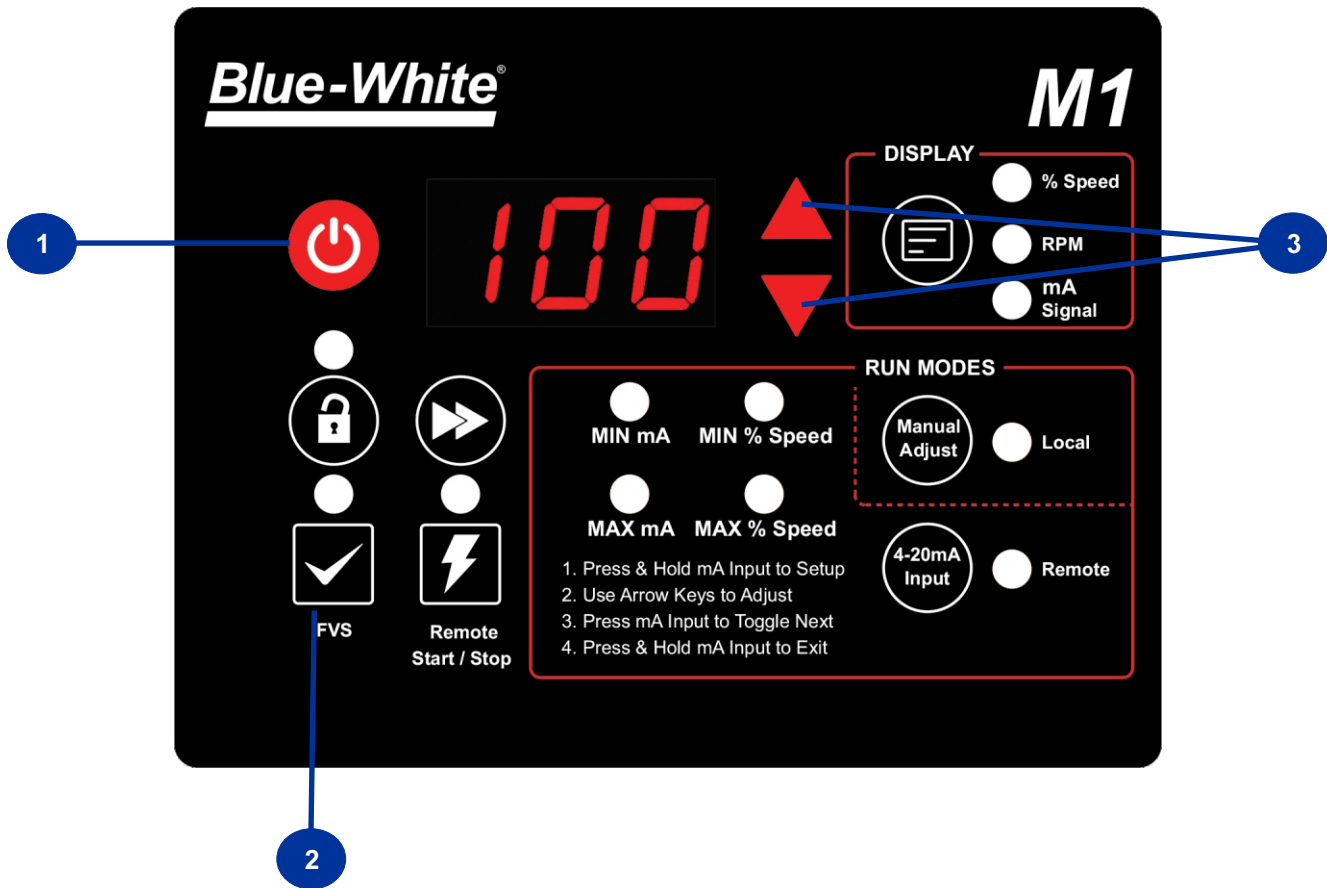

Item Number	Directions for Programming FVS
1	Confirm that pump is in the OFF position
2	Press and hold FVS button (5-7 seconds)
3	Toggle up/down arrow to set Delay Time
4	Press and hold FVS button (5-7 seconds)

Activate by pressing FVS button once. Light On indicates activation. Press again to de-activate.

NOTE: Alarm Delay Time range 1-20 seconds

7.3 Pump Lockout

Pump Lockout feature allows the user to “lock out” the ability to change pump controls, such as Pump Speed, Prime, FVS, Remote Start/Stop, Manual/4-20ma Modes. User will still be able to start and stop the pump.

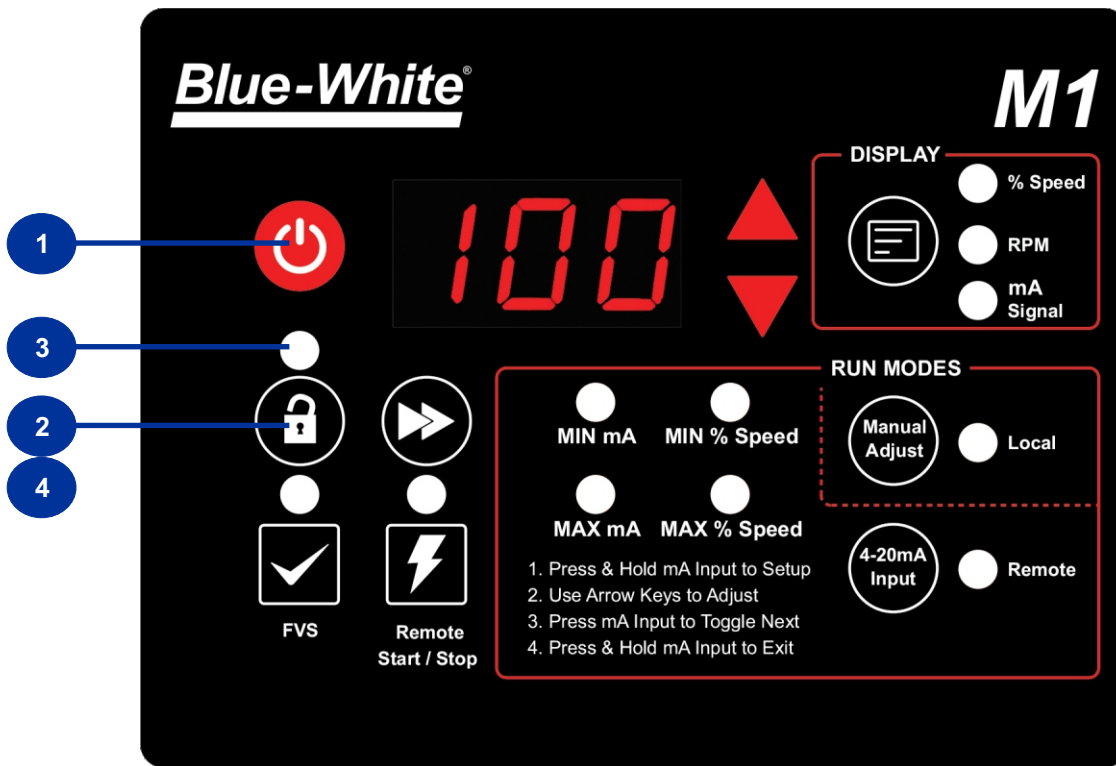

Item Number	Directions
1	Pump can be running or in the OFF position
2	Press and hold Lockout button (5-7 seconds)
3	Light will activate
4	To de-activate, press and hold Lockout button (5-7 seconds)

7.4 4-20mA Input

Selecting 4-20mA Input Mode

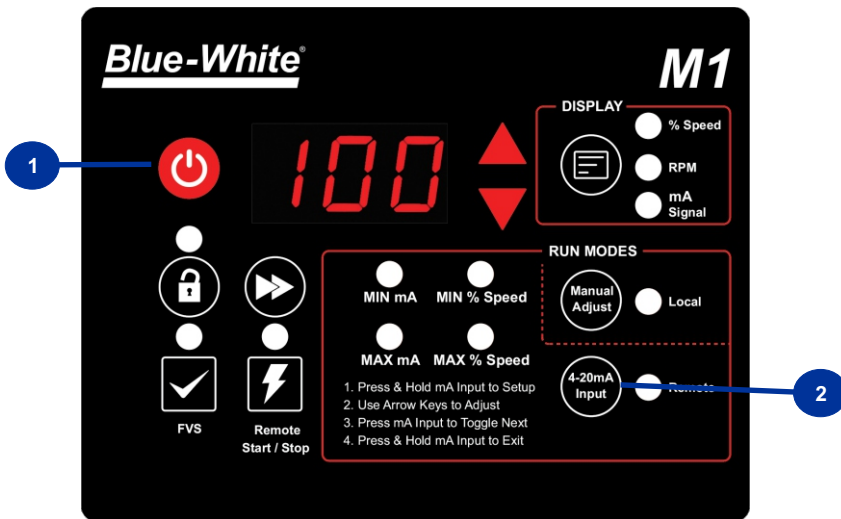

Directions

- 1 Confirm that pump is in the OFF position
- 2 Press 4-20mA Input button

Programming 4-20mA Input Mode

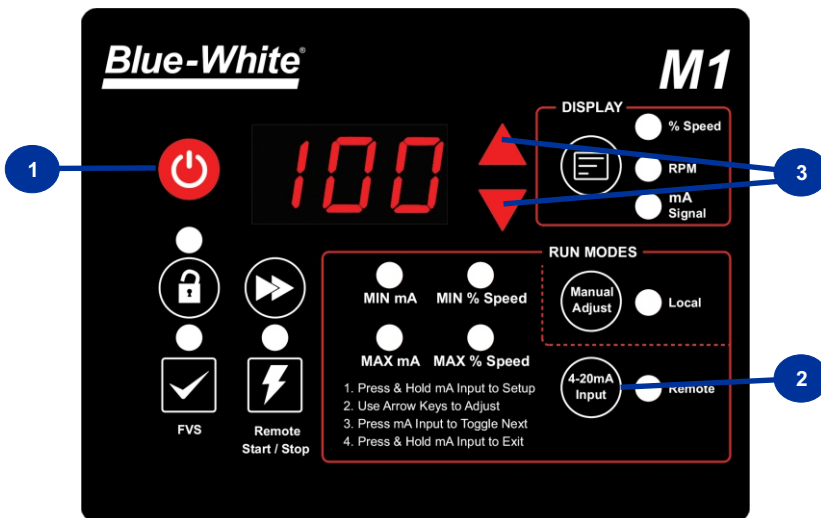

Directions

- 1 Confirm that pump is in the OFF position.
- 2 Press and hold 4-20mA Input button.
- 3 MIN mA light will illuminate. Use arrow keys to toggle min mA value for the pump to operate at
- 4 Press 4-20mA Input button for MIN % Speed light to illuminate
- 5 Use arrow keys to toggle MIN % Speed value for the pump to operate.
- 6 Press 4-20mA Input button for MAX mA light to illuminate.
- 7 Use arrow keys to toggle MAX mA value for the pump to operate.
- 8 Press 4-20mA Input button for MAX % Speed light to illuminate.
- 9 Use arrow keys to toggle MAX % Speed value for the pump to operate.
- 10 Press and hold 4-20mA Input button to exit programming mode.

8.0 PUMP OPERATION

8.1 Priming The Pump

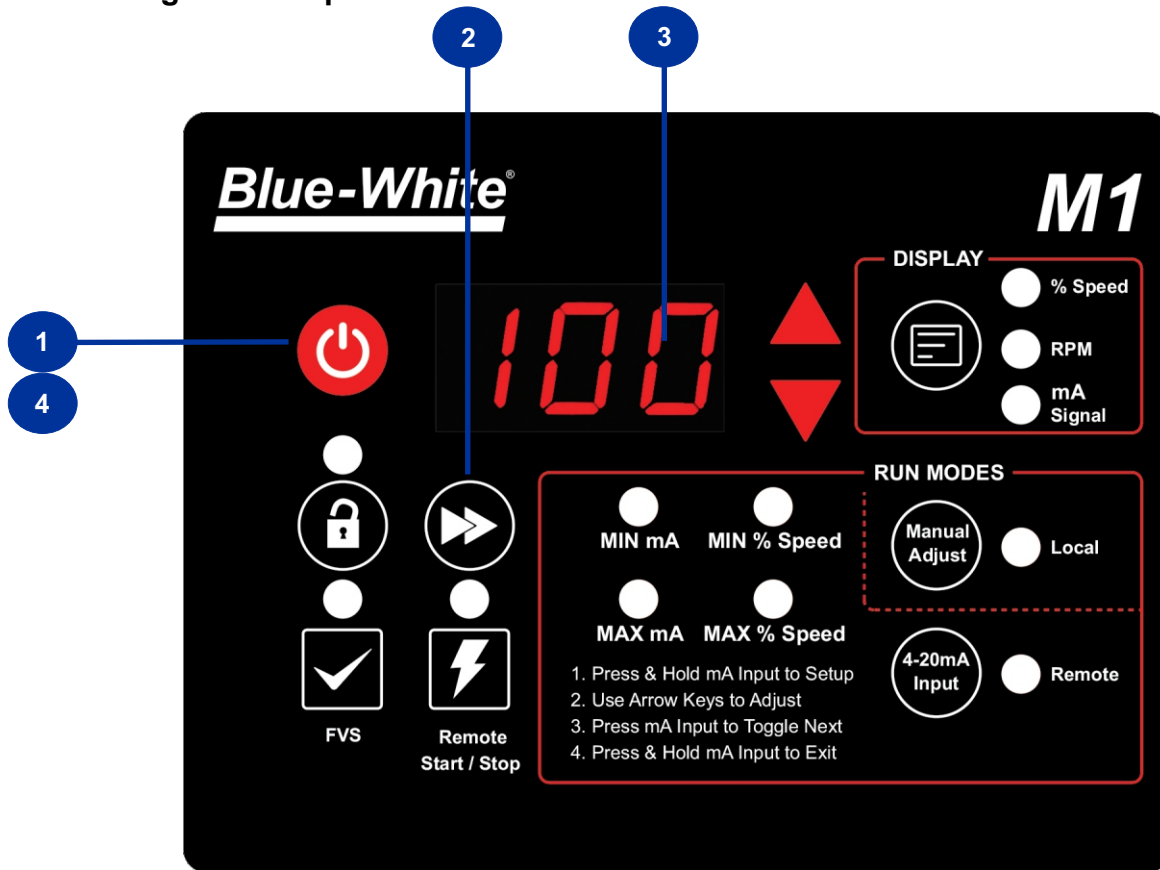

Item Number	Directions
1	Pump can be running or in the OFF position
2	Press Prime button
3	Pumps will run at 100% speed and Display will count down from 60 seconds
4	Press Start/Stop button at any time to Stop pump

Need help calibrating your pump?
Click on ... or scan the QR code.



8.2 Manual Pump Operation

Pump speed can be adjusted manually using “Manual Adjust” Run Mode.

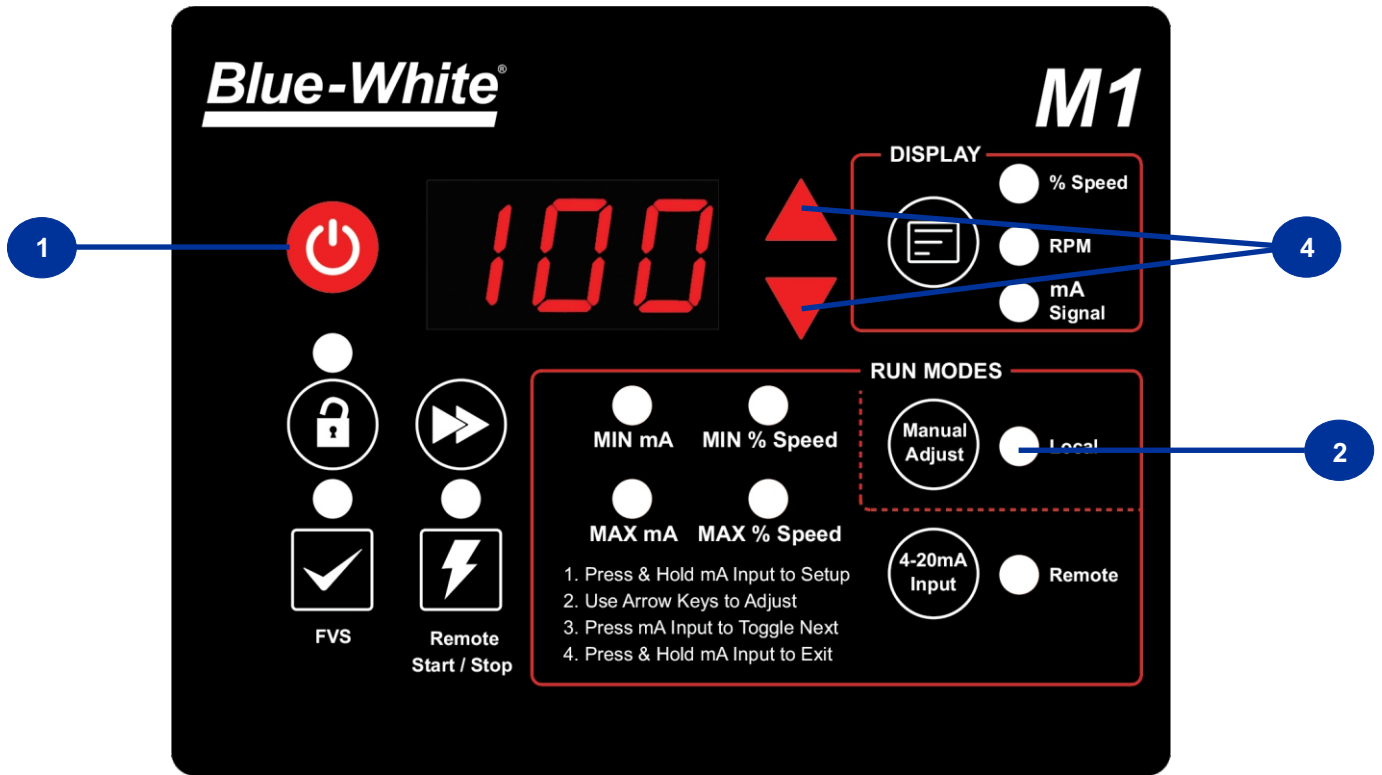

Item Number	Directions
1	Confirm that pump is in the OFF position
2	Press “Manual Adjust” button. Local light will activate.
3	Press Start/Stop button.
4	Adjust pump speed using up and down arrows

8.3 4-20 Input Speed Control

Pump speed can be adjusted remotely using “4-20ma Input” Run Mode.

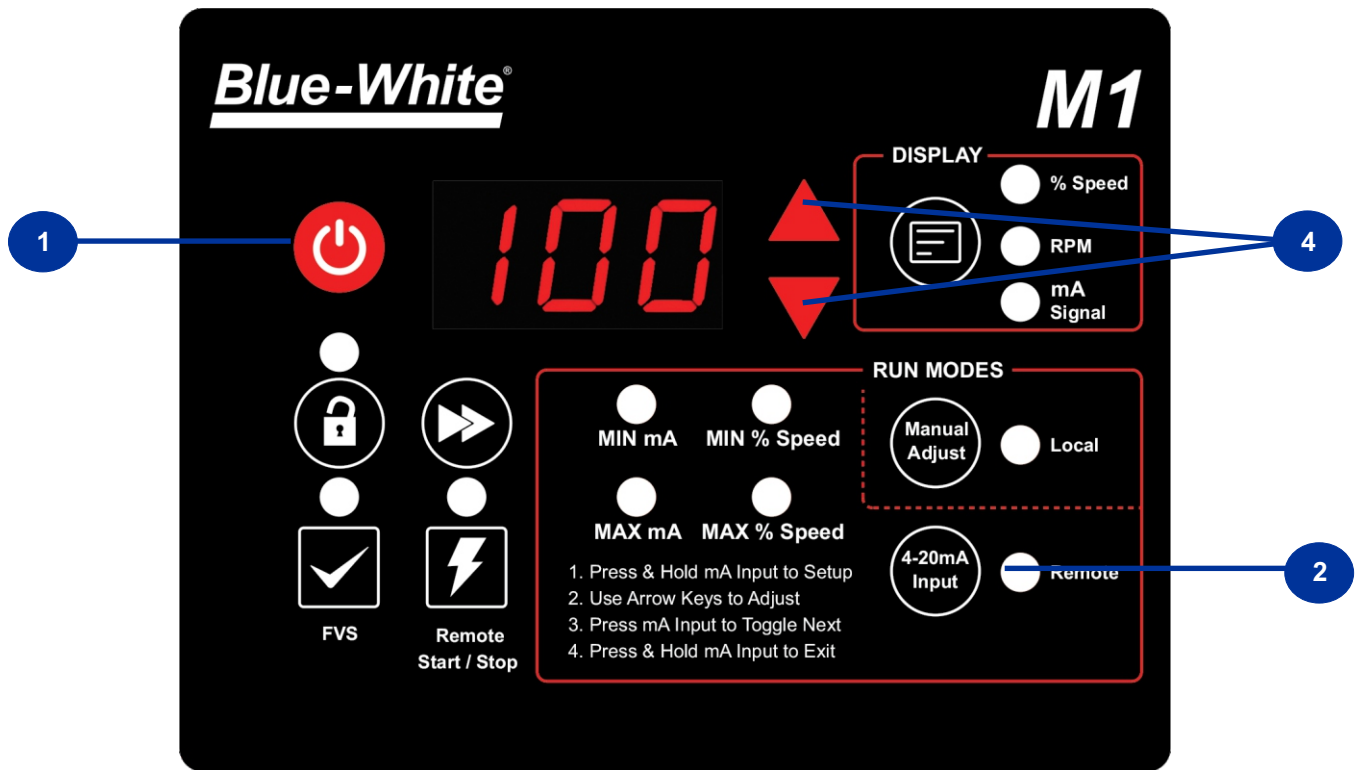

Item Number	Directions
1	Confirm that pump is in the OFF position
2	Press “4-20ma Input” button. Remote light will activate.
3	Press Start/Stop button.
4	Pump speed will be adjusted by 4-20ma input signal
5	Adjust up and down arrows to display % speed, RPM, or 4-20mA input signal

9.0 OUTPUTS

- MOTOR ON** - Active when motor is running in Manual or 4-20ma Mode.
- RELAY OUTPUT** - Active when either TFD or FVS has triggered. Stop pump to reset.
- 4-2mA OUTPUT** - Non-scalable full scale output proportional to pump speed.

10.0 ENHANCED TUBE FAILURE DETECTION (TFD+)

The pump is equipped with a Enhanced Tube Failure Detection (TFD+) system, which is designed to stop the pump and provide an output alarm in the event the pump tube should rupture, and a chemical enters the pump head.

This TFD+ system can detect the presence of many chemicals, including sodium hypochlorite (chlorine), hydrochloric (muriatic) acid, sodium hydroxide, oils based polymers, water based polymers, and many others. The system will not be triggered by water (rain, condensation, etc.) or silicone oil (roller lubricant).

NOTE: If the system has detected a chemical, the pump tube must be replaced, and the pump head and roller assembly must be thoroughly cleaned. Failure to clean the roller assembly will void the warranty.

NOTE: If the TFD+ alarm is triggered, the pump will stop, and close an alarm output. See M12 Connector details to wire this alarm.

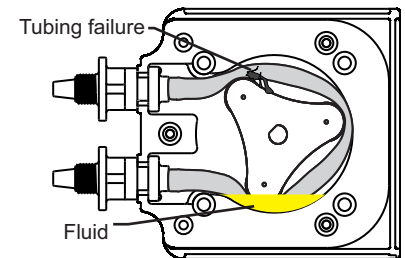

10.1 Confirming Chemical Detection

To determine if a chemical will be detected by the system:

1. Remove the pump head cover, and the pump tube and roller assembly.
2. Place a small amount of chemical in the bottom of the pump head that is enough to cover the sensors.
3. Reinstall **only** the pump head cover.
4. Turn on the pump by pressing the START button.

NOTE: If the TFD+ system **detects** a chemical, the pump will stop after a two-second confirmation period.

NOTE: If the TFD+ system **does not detect** a chemical, the pump will continue to operate after the confirmation period.

5. Carefully clean the chemical out of the pump head. Ensure to remove all the chemical traces from the sensor probes.
6. Replace the roller assembly and tubing.
7. Reinstall the pump head cover.
8. Press the START button to clear the alarm condition.
9. Restart the pump.

11.0 PUMP MAINTENANCE

CAUTION

Always wear protective clothing, face shield, safety glasses and gloves when working on or near your metering pump. Additional precautions should be taken depending on the solution being pumped. Refer to MSDS precautions from your solution supplier.

11.1 Routine Inspection and Maintenance

The pump requires minimal maintenance. However, the pump and all the accessories should be checked weekly, especially when pumping chemicals. Inspect all the components for signs of leaking, swelling, cracking, discoloration, or corrosion. Immediately replace worn out or damaged components.

Cracking, crazing, or discoloration during the first week of operation are signs of a severe chemical attack. If this occurs, perform the following steps:

1. Immediately remove the chemical from the pump.
2. Determine which parts are being attacked.
3. Replace the damaged parts with parts that have been manufactured using more suitable materials.
4. After servicing, operate the pump to verify normal operation.

NOTE: The manufacturer does not assume responsibility for damage to a pump that has been caused by a chemical attack.

11.2 Cleaning and Lubricating the Pump

- ▶ The pump will require occasional cleaning, depending on type of service, operating conditions, and run time.
- ▶ When changing the pump tube assembly, the pump head chamber, the roller assembly, and the pump head cover should be wiped of any dirt and debris.
- ▶ Clean the motor shaft with a clean towel, and then apply a small amount of grease to the shaft. This will help prevent the rotor from sticking to the motor shaft.
- ▶ Periodically, or when necessary, grease the pump head cover bearing. Apply a small amount of grease (Aeroshell aviation grease #5 or equivalent).
- ▶ 100% silicone lubrication may be used on the roller assembly.
- ▶ Periodically clean the injection fitting /check valve assembly, especially since injecting fluids, like sodium hypochlorite, can calcify. These lime deposits and other buildups can clog the fitting, increase back pressure, and interfere with the check valve operation.
- ▶ Periodically clean the suction strainer.

Not Sure ... Watch Instructional Video

Click on ... or scan QR code.



12.0 TUBE REPLACEMENT

CAUTION



Prior to service, pump clean water through the pump and suction / discharge line to remove any chemical.

CAUTION



Always wear protective clothing, face shield, safety glasses and gloves when working on or near your metering pump. Additional precautions should be taken depending on solution being pumped. Refer to MSDS precautions from your solution supplier.

CAUTION



Use the provided Tube Installation Tool to leverage tubing into the pump head. **Do not use your fingers.**

CAUTION



Use extreme caution when replacing the pump tube. **Do not place your fingers near the rollers.**

The pump tube assembly will eventually become non-operational if it is not regularly inspected and replaced. The tube life is affected by many factors, such as the type of chemical being pumped, the amount of back pressure, the motor revolutions per minute (RPM), and temperature.

12.1 Tube Removal

CAUTION



Safety first. Remove the pressure. Relieve (remove) the system pressure on the discharge and suction side of the pump. Failure to do so will cause the solution to squirt when disconnecting the tube connections.

1. Disconnect the system plumbing from the pump tube adapters.
2. Press the Start/Stop key to stop the pump.
3. Remove the three black thumb screws from the front of the pump head cover by unscrewing counterclockwise. Remove the pump head cover by pulling straight out.



4. **Set the motor speed to 10%.** Press the Start/Stop key to start the pump.
5. With the pump running, pull the inlet (suction) fitting out of the pump head. Guide the tube counterclockwise away from the rollers. Pull the outlet (discharge) fitting out of the pump head.



6. Press the Start/Stop key to stop the pump.



12.2 Tube Installation

NOTE: Thoroughly clean the pump head and rotor. The rotor can be removed by pulling it straight out. After cleaning, push the rotor back on the shaft.

1. **Set the motor speed to 10%.** Press the Start/Stop key to start the pump.
2. Insert the inlet (suction) side of the pump tube fitting into the lower retaining slot of the pump head. Carefully guide the pump tube into the pump head.



3. Stretch the tube slightly and insert the outlet (discharge) fitting into the upper retaining slot of the pump head. Pull the tube installation tube out of the pump head.



4. Place the clear cover onto the pump head. Secure the cover with the provided three thumb screws. The pump is now ready for operation.



Not Sure ... Watch Instructional Video

Click on ... or scan QR code.



13.0 Updating The Firmware

REQUIREMENTS: Download & Install the M1 Programmer file by visiting the Firmware Update section of the M1 product page at www.blue-white.com as well as download the Firmware Update File.

1. Connect the Pump to a computer via USB-A / USB-C cable (Pump must not be powered before starting.) (Be sure to replace USB cover after updating firmware)
2. Power up the Pump
3. Open the M1 programmer
4. Select “Enable” USB in the Communication settings window
5. Click on Connect



[Watch this Video for further assistance.](#)

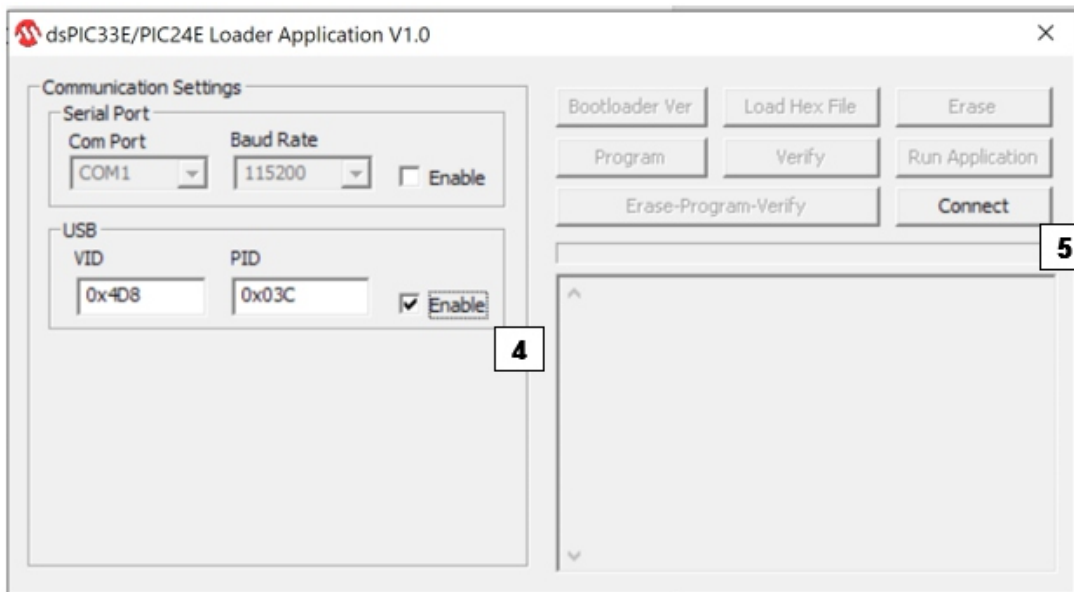

6. Select “Load Hex File”

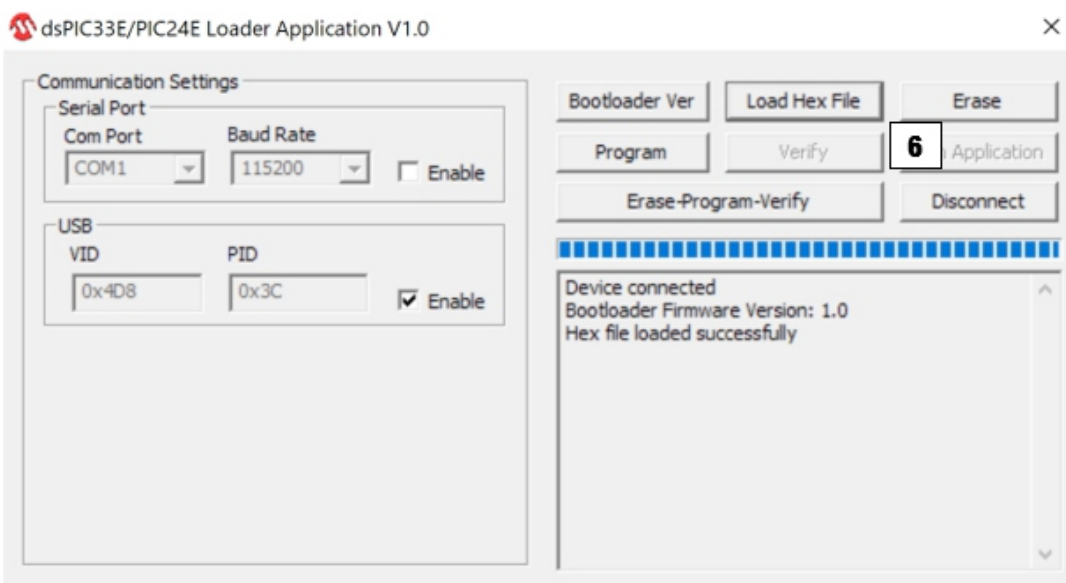

7. Select “.HEX” file (See Blue-White website for latest version)



M1-xxx.hex

8. Click on “Erase-Program-Verify”

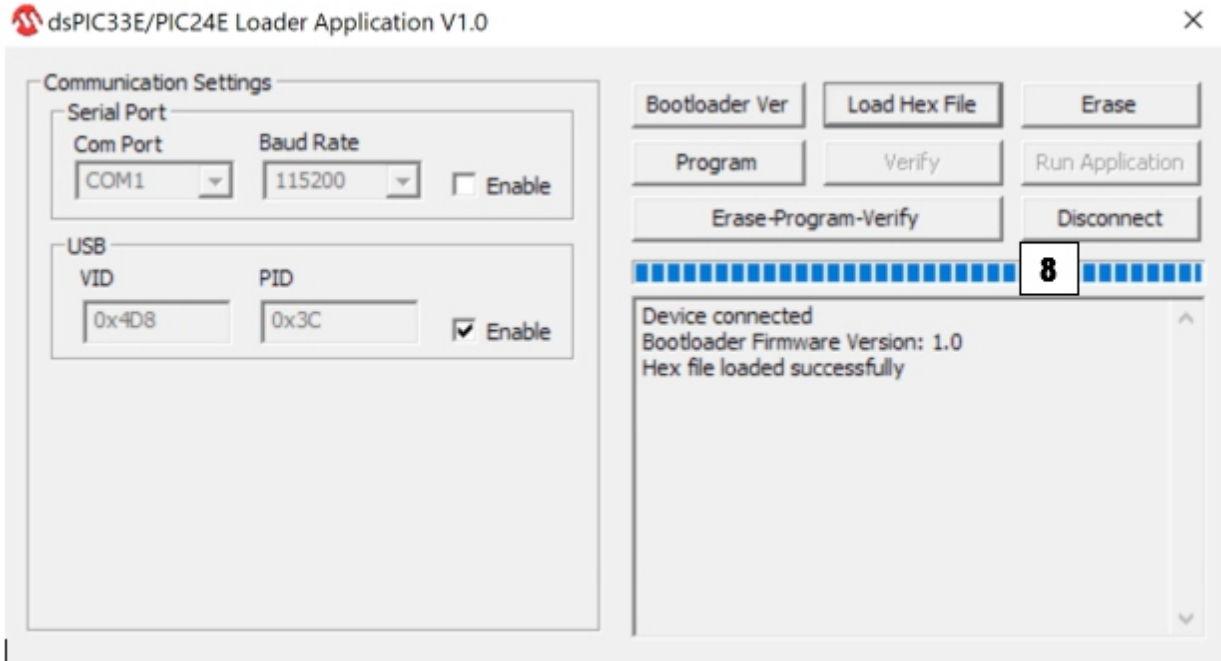

9. Once Hex file is loaded successfully
10. Click on “Disconnect”. Your firmware has now been updated.

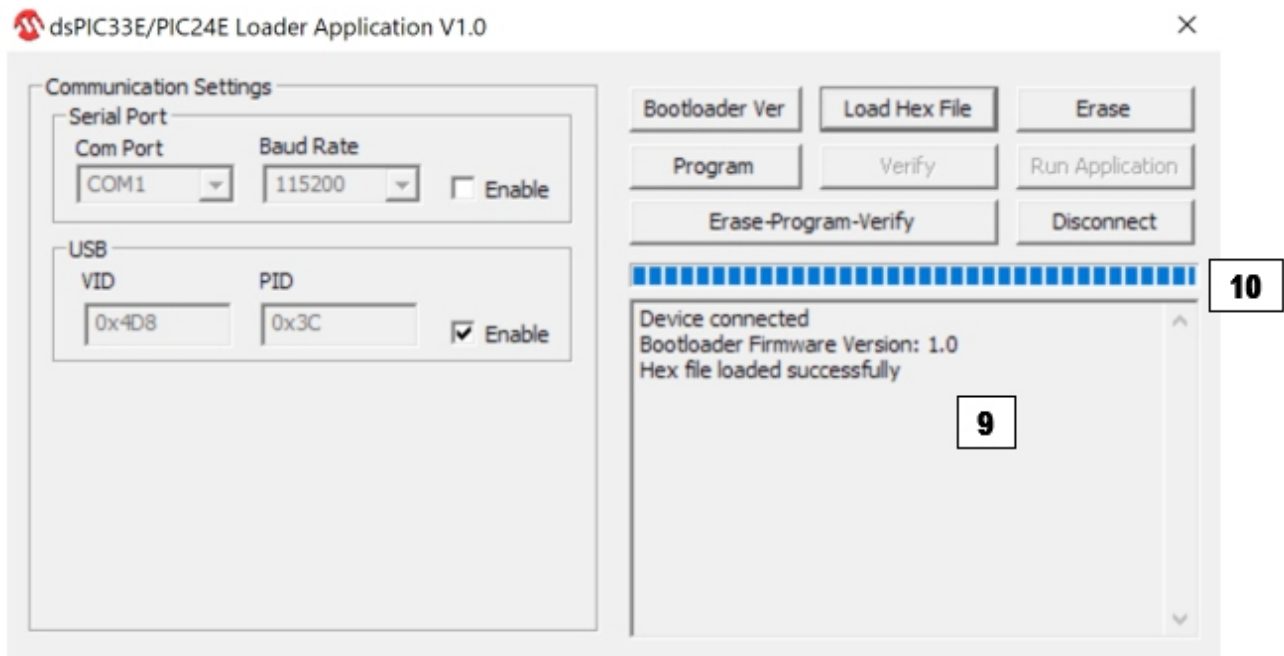

14.0 REPLACEMENT PARTS LIST

Item	Description	Part	Quantity
1	Spacer, back	90011-014	1
2	Roller assembly complete (rotor) A1-1T, A1-2T, A1-3T, A1-7T	71000-350	1
	Roller assembly complete (rotor) A1-6T, A1-4T	71000-159	
	Roller assembly complete (rotor) A1-8T	71000-255	
3	Tube assembly, 1/4" OD, Flex-A-Thane®	A1-1*	2
	Tube assembly, 7/16" OD, Flex-A-Thane®	A1-3*	
	Tube assembly, 1/4" OD, Flex-A-Prene®	A1-4*	
	Tube assembly, 3/8" OD, Flex-A-Prene®	A1-6*	
	Tube assembly, 7/16" OD, Flex-A-Prene®	A1-7*	
	Tube assembly, 7/16" OD, Flex-A-Chem®	A1-8*	
4	Pump head cover, Acrylic	A1-SXX-C	1
5	Thumb screw with 9/64" key drive, maximum torque 6-8 in. lbs.	90011-160	3
6	Tube nut, compression, for 3/8" tubing	C-330-6	2
7	Cover M1 Polycarbonate (not pictured)	90002-684	1

NOTES:

* - Designate "T" Tube Compression, or "M" 1/2" MNPT connection types when ordering.

14.1 EXPLODED VIEW

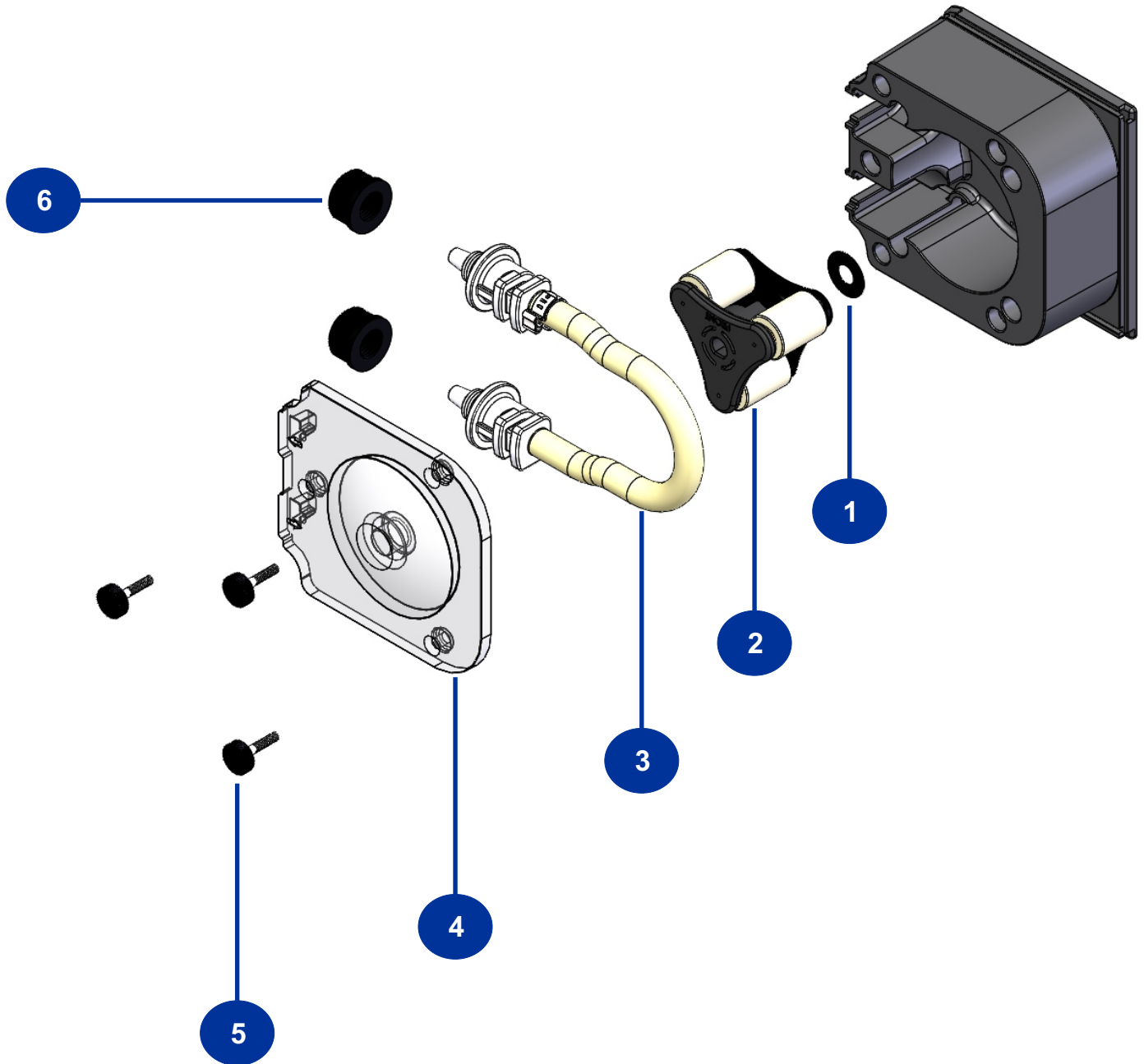

15.0 ACCESSORIES

The following accessories are available for the M1 FLEXFLO® Peristaltic Metering Pump. Please visit Blue-white.com for more information. All accessories are sold separately.



KIT-M12
TWO M12 CABLES

KIT-M12

Kit contains: Two M12 cables. 10 foot length.
Other cable lengths:
KIT-M12-2-15 15 foot length.
KIT-M12-2-30 30 foot length.

KIT-M12 WIRING INSTRUCTIONS		
DIAGRAM	PIN #	WIRE COLOR
	PIN 1	BROWN
	PIN 2	WHITE
	PIN 3	BLUE
	PIN 4	BLACK
	PIN 5	GRAY

NOTE: THIS DIAGRAM IS FOR THE PUMP'S M12 PORT



KIT-M12-3
THREE M12 CABLES

KIT-M12-3

Kit contains: Three M12 cables. 10 foot length.
Other cable lengths:
KIT-M12-3-15 15 foot length.
KIT-M12-3-30 30 foot length.



CABLE-UAC
USB A-C CABLE

CABLE-UAC

Kit contains: One 3' USB-A to USB-C cable.

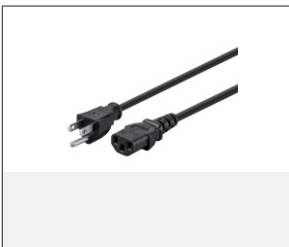

POWER CORDS - DETACHABLE

- 90010-663 115V/60Hz NEMA 5/15
- 90010-664 220V/50Hz CEE 7/V11
- 90010-665 230V/50Hz BS 1363/A
- 90010-666 240V/50Hz AS 3112
- 90010-696 230V/60Hz NEMA 6/15
- 90010-821 115V/60Hz NEMA 5/15 (Lockable)

NOTE: All Accessories are sold separately



SUCTION AND DISCHARGE TUBING

C-334-6	Tubing, Suction, clear PVC 3/8" O.D. x 5' length
C-334-6-10	Tubing, Suction, clear PVC 3/8" O.D. x 10' length
C-334-6-100	Tubing, Suction, clear PVC 3/8" O.D. x 100' length
C-335-6	Tubing, Discharge, opaque PE 3/8" O.D. x 5' length
C-335-6-10	Tubing, Discharge, opaque PE 3/8" O.D. x 10' length
C-335-6-100	Tubing, Discharge, opaque PE 3/8" O.D. x 100' length



KIT-S07

Kit contains: One 7 gallon tank, One 3/8" suction tube, One 3/8" discharge tube, One foot valve and strainer and One mounting bracket with screws



KIT-S15

Kit contains: One 15 gallon tank, One 3/8" suction tube, One 3/8" discharge tube, One foot valve and strainer and One mounting bracket with screws



KIT-S30

Kit contains: One 30 gallon tank, One 3/8" suction tube, One 3/8" discharge tube, One foot valve and strainer and One mounting bracket with screws



KIT-PSM

Kit contains: One HDPE Bracket, (4) 3/8" x 2-3/4" long dia anchor bolts.

16.0 TROUBLESHOOTING

Error Code	Explanation	Troubleshooting
E01	Motor Over Current	Check that tube is installed correctly
E02	Over Voltage	Check power supply output voltage
E03	Under Voltage	Check power supply output voltage
E04	Temperature exceeds 75°C at control	Check ambient conditions, restart pump once cooled to ambient temperature
E05	Inverter Error	Contact Blue-White Industries (714) 893-8529 customerservice@blue-white.com
E06	No Motor Connection	Contact Blue-White Industries (714) 893-8529 customerservice@blue-white.com
E08	Motor Stall	Check that tube is properly installed
E10	Capacitor bank charging error	Contact Blue-White Industries (714) 893-8529 customerservice@blue-white.com
E17	Communication error at display	Contact Blue-White Industries (714) 893-8529 customerservice@blue-white.com

17.0 WARRANTY

17.1 LIMITED WARRANTY

Your new FLEXFLO pump is a quality product and is warranted for 60 months from date of purchase (proof of purchase is required). The pump will be repaired or replaced at our discretion. Failure must have occurred due to defect in material or workmanship and not as a result of operation of the product other than in normal operation as defined in the pump manual. Warranty status is determined by the pump's serial label and the sales invoice or receipt. The serial label must be on the pump and legible. The warranty status of the pump will be verified by Blue-White or a factory authorized service center.

Pump Head and roller assembly is warranted against damage from chemical attack when proper TFD+ (Tube Failure Detection) system instructions and maintenance procedures are followed.

17.2 WHAT IS NOT COVERED

- Pump Tube Assemblies and rubber components – They are perishable and require periodic replacement.
- Pump removal, or re-installation, and any related labor charge.
- Freight to the factory, or service center.
- Pumps that have been tampered with, or in pieces.
- Damage to the pump that results from misuse, carelessness such as chemical spills on the enclosure, abuse, lack of maintenance, or alteration which is out of our control.
- Pumps damaged by faulty wiring, power surges or acts of nature.

17.3 PROCEDURE FOR IN WARRANTY REPAIR

Contact the factory to obtain a RMA (Return Material Authorization) number. Carefully pack the pump to be repaired. It is recommended to include foot strainer and injection/check valve fitting since these devices may be clogged and part of the problem. Please enclose a brief description of the problem as well as the original invoice or sales receipt, or copy showing the date of purchase. Prepay all shipping costs. COD shipments will not be accepted. Warranty service must be performed by the factory or an authorized service center. Damage caused by improper packaging is the responsibility of the sender. When In-Warranty repair or replacement is completed, the factory pays for return shipping to the dealer or customer.

17.4 PRODUCT USE WARNING

Blue-White products are manufactured to meet the highest quality standards in the industry. Each product instruction manual includes a description of the associated product warranty and provides the user with important safety information. Purchasers, installers, and operators of Blue-White products should take the time to inform themselves about the safe operation of these products. In addition, Customers are expected to do their own due diligence regarding which products and materials are best suited for their intended applications. Blue-White is pleased to assist in this effort but does not guarantee the suitability of any particular product for any specific application as Blue-White does not have the same degree of familiarity with the application that the customer/end user has. While Blue-White will honor all of its product warranties according to their terms and conditions, Blue-White shall only be obligated to repair or replace its defective parts or products in accordance with the associated product warranties. **BLUE-WHITE SHALL NOT BE LIABLE EITHER IN TORT OR IN CONTRACT FOR ANY LOSS OR DAMAGE WHETHER DIRECT, INDIRECT, INCIDENTAL, OR CONSEQUENTIAL, ARISING OUT OF OR RELATED TO THE FAILURE OF ANY OF ITS PARTS OR PRODUCTS OR OF THEIR UNSUITABILITY FOR A GIVEN PURPOSE OR APPLICATION.**

17.5 CHEMICAL RESISTANCE WARNING

Blue-White offers a wide variety of wetted parts. Purchasers, installers, and operators of Blue-White products must be well informed and aware of the precautions to be taken when injecting or measuring various chemicals, especially those considered to be irritants, contaminants or hazardous. Customers are expected to do their own due diligence regarding which products and materials are best suited for their applications, particularly as it may relate to the potential effects of certain chemicals on Blue-White products and the potential for adverse chemical interactions. Blue-White tests its products with water only. The chemical resistance information included in this instruction manual was supplied to Blue-White by reputable sources, but Blue-White is not able to vouch for the accuracy or completeness thereof. While Blue-White will honor all of its product warranties according to their terms and conditions, Blue-White shall only be obligated to repair or replace its defective parts or products in accordance with the associated product warranties. **BLUE-WHITE SHALL NOT BE LIABLE EITHER IN TORT OR IN CONTRACT FOR ANY LOSS OR DAMAGE, WHETHER DIRECT, INDIRECT, INCIDENTAL, OR CONSEQUENTIAL, ARISING OUT OF OR RELATED TO THE USE OF CHEMICALS IN CONNECTION WITH ANY BLUE-WHITE PRODUCTS.**

APPENDIX A: ACRONYMS

°C	Celsius	RMA	Return Material Authorization
°F	Fahrenheit	RPM	Revolutions per minute
AC	Alternating current	SIP	Steam-in-place
bar	Unit of pressure	SS	Solid state
CIP	Clean-in-place	TFD+	Enhanced Tube Failure Detection
cm	Centimeters	TFE/P	Tetrafluoroethylene propylene
COD	Cash on Delivery	UL	Underwriters Laboratories
D	Depth	US	United States
DC	Direct current	V	Volt
EEE	Electrical and electronic equipment	W	Watt
EP	Ethylene propylene	W	Width
ETL	Electrical Testing Labs/Intertek	WEEE	Waste Electrical and Electronic Equipment
EU	European Union		
FDA	Food and Drug Administration		
FKM	Fluoroelastomer		
FVS	Flow Verification Sensor		
GF	Glass fiber		
GPD	Gallons per day		
GPH	Gallons per hour		
H	Height		
Hz	Hertz		
ID	Inside diameter		
IO	Input/Output		
Kg	Kilogram		
lb.	Pound		
LLDPE	Linear low-density polyethylene		
LPH	Liters per hour		
mA	Milliampere		
min	Minute		
mL	Milliliters		
MSDS	Material Safety Data Sheet		
N.C.	Normally Close		
N.O.	Normally Open		
NPT	National Pipe Thread		
NSF	National Sanitation Foundation		
OD	Outside diameter		
P.N.	Part Number		
PBT	Polybutylene Terephthalate		
PE	Polyethylene		
PSI	Pounds per Square Inch		
PVC	Polyvinyl chloride		
PVDF	Polyvinylidene fluoride		
RCD	Residual-current device		
Rev.	Revision		

Model Number Matrix

FLEXFLO® Model Number

M1	FLEXFLO® Peristaltic Metering Pump				
Power Cord (Operating voltage requirement 96VAC to 264VAC)					
4	115V 50/60Hz, power cord NEMA 5/15 plug (US) (detachable - 6 ft)				
6	220V 50/60Hz, power cord CEE 7/V11 plug (EU) (detachable - 6 ft)				
X	No Power Cord (Power cord is required - See accessories for power cord options)				
Pump Tube Size and Material					
1	1/4" OD Flex-A-Thane® 0.0001 - 1.09 GPH .0069 - 69 mL/Min 65 PSI (4.5 bar)				
3	7/16" OD Flex-A-Thane® 0.0005 - 5.60 GPH .0353 - 353 mL/Min 50 PSI (3.45 bar)				
4	1/4" OD Flex-A-Prene® 0.0001 - 0.44 GPH .0028 - 28 mL/Min 100 PSI (6.89 bar)				
6	3/8" OD Flex-A-Prene® 0.0001 - 1.35 GPH .0085 - 85 mL/Min 100 PSI (6.89 bar)				
7	7/16" OD Flex-A-Prene® 0.0004 - 4.17 GPH .0263 - 263 mL/Min 50 PSI (3.45 bar)				
8	7/16" OD Flex-A-Chem® 0.0003 - 3.09 GPH .0195 - 195 mL/Min 50 PSI (3.45 bar)				
Inlet/Outlet Connection Size, Connection Type					
T	3/8" OD x 1/4" ID Tube Compression Fitting				
M	1/2" Male NPT Fitting				
MB	1/2" Male BSPT Fitting, Natural PVDF (Kynar)				
M1	4	-	1	T	Sample Model Number

NOTES:

NOTES:

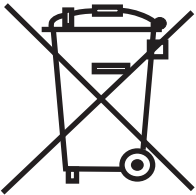

Users of electrical and electronic equipment (EEE) with the WEEE marking per Annex IV of the WEEE Directive must not dispose of end of life EEE as unsorted municipal waste, but use the collection framework available to them for the return, recycle, recovery of WEEE and minimize any potential effects of EEE on the environment and human health due to the presence of hazardous substances. The WEEE marking applies only to countries within the European Union (EU) and Norway. Appliances are labeled in accordance with European Directive 2002/96/EC.

Contact your local waste recovery agency for a *Designated Collection Facility* in your area.

Blue-White[®]

5300 Business Drive
Huntington Beach, CA 92649
USA

TEL: 714-893-8529
FAX: 714-894-9492

www.blue-white.com
sales@blue-white.com
customerservice@blue-white.com